



LOT GRADING GUIDELINES

Site grading shall ensure proper drainage of Commercial and Residential properties establishing an effective surface drainage system for the whole development area. Homes built prior to 2005 are not required to comply but must still have proper lot drainage. A lot grading plan will establish the drainage relationship between adjacent properties and its approval is an effective basis for the control of grading of the properties.

Flooding caused by heavy precipitation, melting snow, or runoff may pose problems for all kinds of properties. Older and newer houses, residential and commercial developments may be at risk for flooding if proper maintenance and precautions are not taken. The City of Spruce Grove encourages all builders and homeowners to take preventive measures to avoid flooding, and has set out standards for drainage and lot grading under the **Surface Drainage Bylaw No. C-1045-18**.

Property owners are responsible for their own lot grading. Check our information about lot grading guidelines, approval inspections, and dispute resolution to ensure that you are taking the right steps to prevent flooding on your property.

Note: The owner of a lot shall comply with the terms and conditions of any restricted covenant, easement agreement, utility right-of-way, caveat or any other document registered on the certificate of title for that lot.

RESIDENTIAL LOT GRADING

Residential lot grading is for all lots that are zoned for, or contains, or is proposed to contain a single detached dwelling, semi-detached dwelling or row house development containing up to four units.

Residential lot grading is confirmed in two stages:

- Rough Grading must be completed and approved by the City within eighteen (18) months of the issuance of a Lot Grading Permit; and
- Final Grading must be completed and approved by the City within twelve (12) months of the rough grade approval.

Applying for Rough Grade Approval:

1. The builder/applicant has the lot surveyed by an Alberta Land Surveyor (ALS) or Professional Engineer, who will submit the lot grading certificate to the City's lot grading inspector.
2. Lot grading certificates must be submitted within twelve (12) months of being completed. The lot grading inspector has the right to request a new certificate as deemed necessary. All lot grade certificates can be emailed directly to lot.grading@sprucegrove.org. Once the City receives the lot grade certificate the

- inspection is placed in the queue and it is assumed that the property is ready for inspection. Inspections are done on a first come, first serve basis.
3. All semi-detached or row house developments where a drainage easement exists must be approved as one dwelling at the rough grade stage to ensure proper drainage from and to all units.
 4. The lot grading inspector will review the lot grading certificate and conduct a visual inspection to verify the lot is graded in accordance with the approved surface drainage plan. The CC valve, third pipe, sidewalk and curb will also be inspected at this time in accordance with the Performance Damage Agreement (see below). The Performance Damage Agreement Deposit will be automatically refunded in full upon issuance of rough grade approval in all areas that have not been issued FAC (Final Acceptance Certificate) with the developer.
 5. The inspection will be completed and a report will be sent to the builder/applicant within five (5) to ten (10) business days; weather dependent.
 6. A door tag is left at the home indicating whether the lot was approved or if deficiencies exist.
 7. If deficiencies exist, the builder/applicant must correct the deficiencies and re-apply for inspection within thirty (30) days of the report date. Fees for re-inspection will apply accordingly (refer to "Fees" section). Re-inspection requests can be emailed directly to lot.grading@sprucegrove.org.
 8. Should the builder/applicant not obtain approval of rough grade prior to commencement of final grade, fines may be issued as set out in 'Schedule A' of the *Surface Drainage Bylaw*.
 9. It is the responsibility of the builder/applicant to provide the inspector access to the site once inspection is requested. Should access not be available when the inspector arrives on site the inspection will be deemed as a failure and a re-inspection must be requested and re-inspection fees may apply.

Applying for Final Grade Approval:

1. Confirm with your homebuilder that rough grade approval has been granted and a copy of the rough grade report can be obtained upon request from your builder.
2. Rough grade generally has an allowance of up to 3-8" (7-20 cm) from base to final grade elevation. Topsoil or clay can now be added, spread out and compacted, ready for sod, rock, bark chip, etc. The ground elevation of the topsoil or clay that sod, rock or bark chips will be placed on should be at the same height to avoid pooling of water in these areas (topsoil to clay to topsoil should be level).
3. Prior to sod, rock or bark chips, etc., call a surveyor to resurvey your property. Your ground elevations should now be within 2-6" (5-10 cm) of the final design elevations for your lot (see **Acceptable As-Built Tolerances** section for more information). The surveyor will email the completed final grade certificate to the City's lot grading inspector.
4. Lot grading certificates must be submitted within twelve (12) months of being completed. The lot grading inspector has the right to request a new certificate as deemed necessary. All lot grade certificates can be emailed directly to lot.grading@sprucegrove.org. Once the City receives the lot grade certificate the inspection is placed in the queue and it is assumed that the property is ready for inspection. Inspections are done on a first come, first serve basis.
5. When the builder is completing final grade all semi-detached or row house developments where a drainage easement exists must be approved as one dwelling to ensure proper drainage from and to all units.
6. The lot grading inspector will review the lot grading certificate and conduct a visual inspection to verify the lot is graded in accordance with the approved surface drainage plan. The inspection will be completed and report and copy of the final grade certificate will be sent to the applicant/owner within five (5) to ten (10) business days; weather dependent.
7. A door tag is left at the home indicating whether the lot was approved or if deficiencies exist.
8. If deficiencies exist, the applicant/owner must correct the deficiencies and re-apply for inspection within thirty (30) days. Fees for re-inspection will apply accordingly (refer

- to "Fees" section). All re-inspection requests can be emailed directly to lot.grading@sprucegrove.org .
9. Should the applicant/owner not obtain approval of rough grade prior to commencement of final grade, fines may be issued as set out in 'Schedule A' of the *Surface Drainage Bylaw*.
 10. It is the responsibility of the applicant/owner to provide the inspector access to the site once inspection is requested. Should access not be available when the inspector arrives on site the inspection will be deemed as a failure and a re-inspection must be requested and re-inspection fees may apply.

COMMERCIAL LOT GRADING

Commercial lot grading is for lots that are zoned for, or contains or are proposed to contain a commercial, industrial or multi-family development.

Commercial lot grading is confirmed in one stage:

- Final Grading must be completed and approved by the City within twenty-four (24) months of the issuance of a Lot Grading Permit.

Applying for Final Grade Approval:

1. The builder/applicant has the lot surveyed by an Alberta Land Surveyor (ALS), who will submit the lot grading certificate to the City' lot grading inspector.
2. The builder/applicant must also submit as-built drawings prepared by and Alberta Land Surveyor (ALS) or Professional Engineer.
3. Lot grading certificates must be submitted within twelve (12) months of being completed. The lot grading inspector has the right to request a new certificate as deemed necessary. All lot grade certificates can be emailed directly to lot.grading@sprucegrove.org. Once the City receives the lot grade certificate the inspection is placed in the queue and it is assumed that the property is ready for inspection. Inspections are done on a first come, first serve basis.
4. The lot grading inspector will review the lot grading certificate and as-built drawings and conduct a visual inspection to verify the lot is graded in accordance with the approved site grading plan. The CC valve, third pipe, sidewalk and curb will also be inspected at this time in accordance with the Performance Damage Agreement (see below). The Performance Damage Agreement Deposit will be automatically refunded in full upon issuance of final grade approval in all areas that have not been issued FAC (Final Acceptance Certificate) with the developer.
5. The inspection will be completed and report will be sent to the builder/applicant within fifteen (15) business days; weather dependent.
6. If deficiencies exist, the builder/applicant must correct the deficiencies and re-apply for inspection within sixty (60) days. Fees for re-inspection will apply accordingly (refer to "Fees" section).
7. It is the responsibility of the builder/applicant to provide the inspector access to the site once inspection is requested. Should access not be available when the inspector arrives on site the inspection will be deemed as a failure and a re-inspection must be requested and re-inspection fees may apply

DECORATIVE MATERIAL IN FINAL GRADING

Where rocks, wood chips or other decorative material is used in your landscaping plan, the clay base (rough grade) must be raised to final grade before placing the decorative material down. Rock or wood chips do not make up for the ten (10) to fifteen (15) centimeters of final grade, since surface water can flow through the material.

Below is an example of typical side-lot grading.

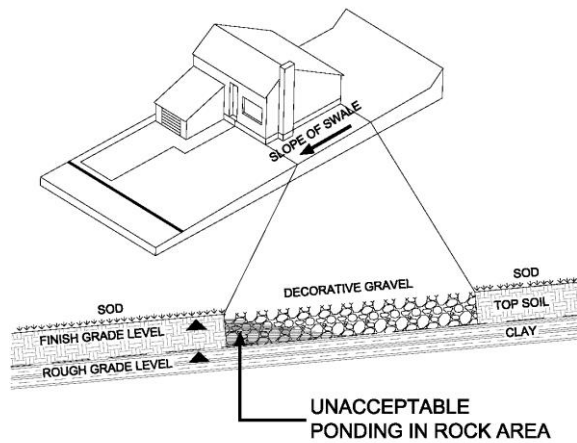

PLACING DECORATIVE ROCK ON THE BASE (CLAY ROUGH GRADE) WILL CREATE A PLACE FOR WATER TO POND.

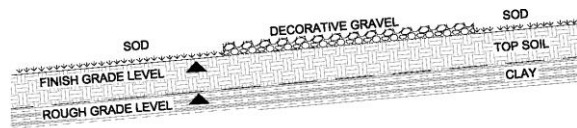

RAISING THE BASE TO FINAL GRADE BEFORE PLACING DECORATIVE ROCK WILL MINIMIZE OR ELIMINATE PONDING.

SWALES

Drainage swales are shallow-sided, sloped ditches designed to convey surface run-off away from buildings towards the nearest street, lane, dry pond or storm water management facility to prevent lot-to-lot drainage. Typically, property line swales are shared by adjacent properties, and serve to provide surface drainage for both lots. Internal swales may also be present on the lot and must also be maintained by the home owner. All swales should be graded in accordance with an approved Lot Grading Plan and homeowners must ensure they are kept clean, unobstructed and free of debris to ensure drainage is not blocked. In some areas, an easement or right-of-way is required for grass or concrete drainage swales. Easements are shown on the approved Lot Grading Plan.

SURFACE TYPE	MINIMUM GRADE REQUIREMENT IN DRAINAGE SWALES
Grass	2% slope
Impervious Surface (concrete)	0.75% slope

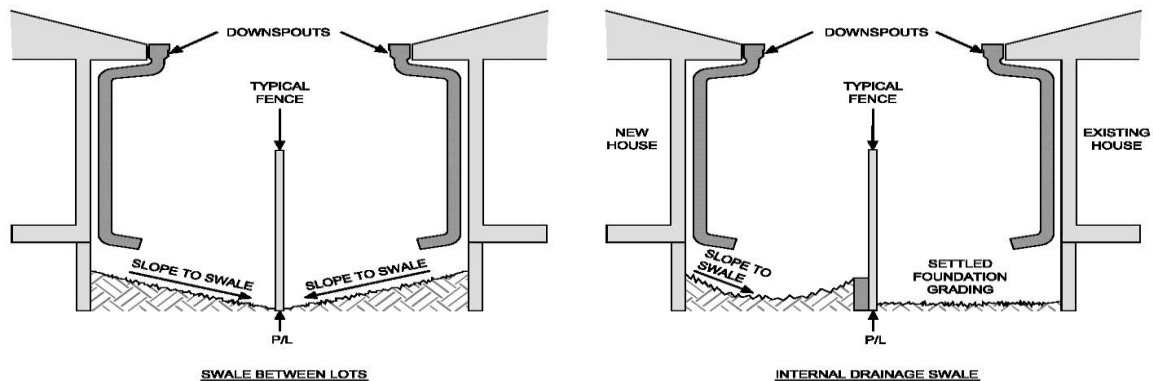

DOWNSPOUTS and SPLASH PADS

Stormwater collected by the eaves troughs is channeled to the ground through downspouts. This results in a concentration of flow at the discharge points that can be substantial. To protect your home as well as your neighbors' homes downspout extensions should project past the backfill zone by approximately 1.0 meters, but must not discharge onto adjacent property. If possible, downspouts should be angled at 45 degrees towards the property line. Downspout extensions should empty onto a splash pad to minimize the foundation zone saturation, which can otherwise increase the risk of water entering the basement (infiltration flooding), or frost heaving any adjacent sidewalks, driveways and/or decks.

Downspout and Splash Pad Requirements

- The downspout must have a hinged elbow or empty onto a splash pad.
- Splash pads are to be placed underneath all downspouts draining onto landscaping (sod, topsoil and/or gravel). Splash pads help to minimize soil erosion.
- The downspout elbow should be directed away from the foundation walls toward the drainage swales along the common property line.
- Downspout extensions or splash pads must not project past the property line.
- Downspouts shall not discharge within 0.3m of any adjacent lot.

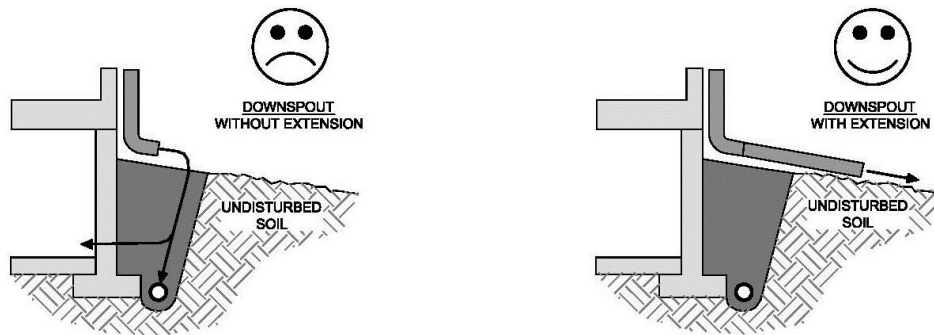

SUMP PUMPS

The sump pump discharge collection system on a home is dedicated to collection of weeping tile system discharges. The emergency sump pump discharge (also known as a third pipe) is an elbow attached to the 100mm storm connection service on the exterior of the home. It is meant as an escape for water if there is blockage in the storm sewer system. To pass inspection, third pipes need to be attached at the 45° downward angle perpendicular to the foundation of the home to ensure any water discharged does not pool beside the foundation.

It is important to provide a splash pad and/or flexible hose below the discharge point. This helps minimize soil erosion at the foundation wall and prevents the re-circulation of the ground water back to the weeping tile. The flexible hose and/or splash pad should be directed to the drainage swales but not onto an adjacent property and shall not discharge within 0.3m from adjacent property. To prevent the sump pump discharge hose from freezing, it should be disconnected during the winter months.

Section V.A.12 of the City of Spruced Grove Municipal Development Standards states that *the system shall be dedicated to the collection of weeping tile flows and other storm water (ie: roof leaders) will not be allowed to connect to the system.*

Note: Engineering Services receives a number of inquiries about excessive sump pump discharging. In the fall and winter, excessive flows result in inconvenient or dangerous icing conditions. To effectively address these concerns, Engineering Services will consider an alternative to discharging sump pump flows onto surface grade.

SCHEMATIC WEeping TILE SUMP PUMP & DISCHARGE

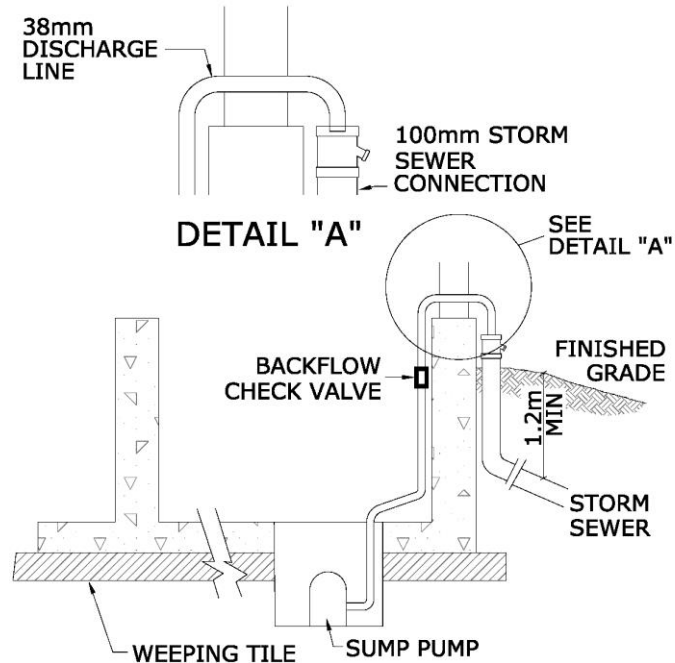

WINDOW WELLS

Depending on location, window wells may be required on some basement windows. If there is a distance of 15cm or greater between the bottom of the window and the top of finished grade, a window well would not be needed. Any window with a distance less than that would require a window well.

LOT GRADING REQUIREMENTS

The following requirements must be met in order to receive rough and final grade approval.

DESIGN GRADES AND EXISTING GRADES

The approved Surface Drainage Plan or Site Grading Plan shows the approved design grades for each lot. These elevations are detailed on the lot grading certificate along with the existing elevations. The existing elevations must be within the tolerances shown below at each respective stage of grading in order to be approved. For example, if a rough grade certificate shows the design grade at 32.30 and the existing grade at 32.16, the tolerance would be -0.14m (or -14cm) below design and approvable.

ACCEPTABLE AS-BUILT TOLERANCES

GRADE	TOLERANCE (metric)	TOLERANCE (imperial)
Rough Grade	-7cm to -20cm	-3" to -8"
Final Grade, on topsoil	-10cm to +5cm	-4" to +2"
Final Grade, on landscaping	-10cm to +10cm	-4" to +4"

*The lot grading inspector has the discretion to accept elevations that are outside of tolerance.

MINIMUM GRADE FROM FOUNDATION WALLS

In order to greatly reduce the risk of water entering basements during periods of heavy precipitation, a sloped surface is required to effectively drain water away from foundation walls; these areas include beneath decks and steps.

SURFACE TYPE	MINIMUM GRADE REQUIREMENT FROM FOUNDATION WALLS
Earth	10% slope required for the first 2 meters
Impervious Surface (concrete)	0.75% slope required for the first 2 meters

REQUIREMENTS UNDER THE PERFORMANCE DAMAGE AGREEMENT

The following requirements must be met before the builder will receive approval on the rough grade and damage inspection report. Damage deposits will not be refunded until the damage inspection has been approved:

- **CURB STOP (CC) VALVE**

The curb stop (cc) valve is typically located in the front or side yard of a home and controls the home's water supply. These valves are put in at the time of subdivision development and can often be damaged during the building process. In order to receive approval on the CC portion of the damage inspection, CC valves need to be operational and installed at final grade elevation which is normally around 10cm-15cm above the approved rough grade elevation.

- **EMERGENCY SUMP PUMP DISCHARGE (THIRD PIPE) INSTALLATION**

As part of the home's foundation drainage system, the emergency sump pump discharge must be installed on the exterior of the home. In order to receive approval on the sump pump portion of the damage inspection, the sump pump is required to have a wye tee, which is an auxiliary discharge pipe on the outside of the home, providing an overflow during a storm sewer back-up. The wye tee must be both unobstructed and capped.

- **SIDEWALK AND CURB CONDITION**

Since sidewalks and curbs are poured at the time of subdivision development, they can become damaged during building construction. At the time the lot grading permit is taken out, builders are required to undertake an initial inspection of the sidewalks and curbs. When the rough grade is inspected, the final damage inspection is completed and compared to the builders' initial inspection. Provided there is no

additional damage to the sidewalks and/or curbs, the builders' damage deposit will be refunded.

MAINTENANCE & ENFORCEMENT

Once Final Grade Approval has been given, it is the owner's responsibility to maintain the surface grades to the standards established at the time of Final Grade Approval. The City may, at any time, require maintenance on the surface grading (lot grading) if alterations or settlements result in surface drainage problems. This requirement is enforceable under the Surface Drainage Bylaw C-1045-18.

Lot Grading Inspection Reports, non-compliance or non-conformance letters or a Notice to Comply are used to advise an owner, builder, contractor or developer of any impending enforcement. Properties that do not comply with the lot grading requirements or Surface Drainage Bylaw provisions will be fined. Non-compliance fines start from \$300 per offence. Each day that the property does not comply may be deemed a separate or subsequent offence. In most cases, notification is sent to the current registered property owner, since the owner is responsible for the maintenance of lot grading.

This bylaw is enforceable for all properties, existing and in deciding whether to enforce this bylaw, the City of Spruce Grove may take into account any practical concerns, complaints and inquiries. Though most complaints are in areas of the city that do not have any Lot Grading Plans, our department does not provide any funding for surface grading repairs. See Surface Drainage Problems for information on how to deal with drainage problems in areas developed before 2005.

SURFACE DRAINAGE PROBLEMS

In some neighbourhoods, complications may arise between neighbours if drainage is not properly designed or if properties are not properly maintained. Most problems can be resolved with open communication. Neighbouring property owners have an equal interest in effective drainage of surface water. The City's representatives (lot grading inspectors) are not mandated to act as dispute arbitrators, but are available to investigate surface drainage problems and enforce the provisions of the Surface Drainage Bylaw No. xxx-xx. If you are experiencing problems, there are several things you can do. A maintenance inspection should include all aspects of surface drainage and any potential impact on adjacent properties:

- Ensure downspouts discharge to the ground surface past the backfill zone but no closer than 0.3m to the adjacent property line.
- Ensure positive slope exists away from foundation walls for a distance of at least 2.0m. A 10% grade is a good target to try to achieve.
- Make sure drainage swales convey water off the lot without impacting adjacent properties. Periodic adjustments may be required as the ground settles over time.
- Ground under steps, decks and build-outs are very susceptible to settling as water doesn't reach these areas, and the clay naturally dries out quicker. Ensure these areas are checked regularly and properly backfilled as needed.
- Window wells should be kept free of debris to ensure efficient drainage.
- Eavestroughs should be cleaned in the spring and fall to ensure unobstructed water flow off the roof and away from the foundation.
- Seal any cracks or separations between sidewalks and foundation walls with a flexible exterior caulking.
- Check your own surface drainage for problems and see our Frequently Asked Questions for answers to your questions about common drainage disputes.

- Talk to your neighbours to work out solutions. They may not realize there is a problem.
- Contact a professional, such as a landscaper or foundation drainage expert.
- If property has been damaged, try mediation before you consider legal action against the offender.

If you're unable to settle on satisfactory drainage arrangements, you can contact the City of Spruce Grove to investigate. A lot grading inspector will examine surface drainage conditions on both properties and make recommendations for improvements. A Letter of Non-Compliance or Notice to Comply will be sent for infractions of the Surface Drainage Bylaw No. xxx-xx. Property owners must then take steps to bring their property in to compliance with the bylaw, or face potential fines.

FEES

Inspection fees are levied only to cover the cost of inspection requirements. These fees are collected at the Planning and Development Department when you apply for the building permit.

PERMIT/INSPECTION TYPE	FEE
Residential Lot Grading Permit	\$165.00
Commercial Lot Grading Permit (commercial, industrial, institutional)	\$200.00 base fee <i>plus</i> \$200.00/ha
Commercial Lot Grading Permit (multi-family)	\$200.00 base fee <i>plus</i> \$50.00 per unit on ground level
Rough Grade Inspection	No charge (included in permit fee)
Rough Grade Re-inspection	\$165.00
Final Grade Inspection	No charge (included in permit fee)
Final Grade Re-inspection (first)	No charge (included in permit fee)
Final Grade Re-inspection (each subsequent)	\$165.00